



Product Datasheet

Longline

SATA Solid State Drive LNGENTPSSD 2TB Product DataSheet





Revision History

Revision	Draft Date	History	Author
1.0	2015/6/10	New release	Golden Lee
1.1	2015/9/1	Add "4" code in X ¹⁴ of P/N decoder	Golden Lee
1.2	2015/10/26	Add quick erase function and X ¹⁶ X ¹⁷ codes in P/N decoder	Golden Lee
1.3	2016/2/17	<ol style="list-style-type: none"> 1. Remove SLC & pSLC support 2. Update environmental tests results 3. Add performance & TBW data for each capacity 	Golden Lee
1.4	2016/4/7	<ol style="list-style-type: none"> 1. Add capacity information 2. Add 2TB data 	Golden Lee
1.5	2016/4/28	Add SLC/pSLC support and update test data	Golden Lee
1.6	2016/12/7	<ol style="list-style-type: none"> 1. Add AES support 2. Remove 1TB pSLC support 	Golden Lee
1.7	2017/12/18	Add SLC 512GB / pSLC 1TB support	Golden Lee
1.8	2017/12/20	Add Power Loss Protection (PLP) function support	Golden Lee
1.9	2019/2/22	Add 3D TLC support	Golden Lee
2.0	2019/12/20	Add 6.4 Write Protect Function support Add Write Protect Function and X ¹⁶ X ¹⁷ codes in P/N decoder	Golden Lee



Product Overview

- **Capacity**
 - SLC: 32GB(30GB) up to 512GB(480GB)
 - MLC: 64GB(60GB) up to 2TB(1920GB)
 - pSLC: 32GB(30GB) up to 1TB(960GB)
 - 3D Bics3: 128GB(120GB) up to 8TB
- **SATA Interface**
 - SATA Revision 3.2
 - SATA 1.5Gbps, 3Gbps, and 6Gbps interface
- **Flash Interface**
 - Flash Type: SLC / MLC / 3D Bics3
- **Performance**
 - Read up to 560 MB/s
 - Write up to 550 MB/s
- **TBW (Terabyte Written)^{Note2}**
 - SLC: 20547 TBW for 512GB
 - MLC: 4114 TBW for 2TB
 - pSLC: 20547 TBW for 1TB
 - 3D Bics3: 3408 TBW for 2TB
- **Power Loss Protection support capacity (only for BGA flash)**
 - SLC: 64GB up to 256GB
 - MLC: 64GB up to 2TB
 - pSLC: 128GB up to 512GB
 - 3D Bics3: 128GB up to 2TB
- **MTBF**
 - SLC: 5,000,000 hours
 - MLC/3D Bics3: 5,000,000 hours
 - pSLC: 5,000,000 hours
- **Power Consumption^{Note1}**
 - Active mode: < 5500mW
 - Idle mode: < 450mW
- **Advanced Flash Management**
 - Static and Dynamic Wear Leveling
 - Bad Block Management
 - TRIM
 - SMART
 - Over-Provision
- **Security (Optional)**
 - AES 256 hardware encryption
- **Low Power Management**
 - DIPM/HIPM Mode
 - Power Loss Protection
- **Temperature Range**
 - Operation (Standard): 0°C ~ 70°C
 - Operation (Wide): -40°C ~ 85°C
 - Storage: -40°C ~ 85°C
- **Compliant**
 - RoHS
 - CE & FCC

Notes:

1. Please see “Power Consumption” for details.
2. Please see “TBW (Terabytes Written)” in chapter 2 for details.



1. INTRODUCTION



1.1. General Description

Longline 2.5" SATA SSD delivers all the advantages of flash disk technology with Serial ATA I/II/III interface, including being fully compliant with standard 2.5-inch form factor, providing low power consumption compared to traditional hard drive and hot-swapping when removing/replacing/upgrading flash disks. The device is designed based on the standard 7-pin interface for data segment and 15-pin for power segment, as well as operating at a maximum operating frequency of 300MHz with 30MHz external crystal. Its capacity could provide a wide range up to 2TB. Moreover, it can reach up to 550MB/s read as well as 530MB/s write high performance based on Toshiba's NAND flash (with 256MB/512MB/1024MB/2048MB DDR3 cache enabled and measured by CrystalDiskMark). Meanwhile, the power consumption of the 2.5" SSD is much lower than traditional hard drives.

1.2. Block Diagram

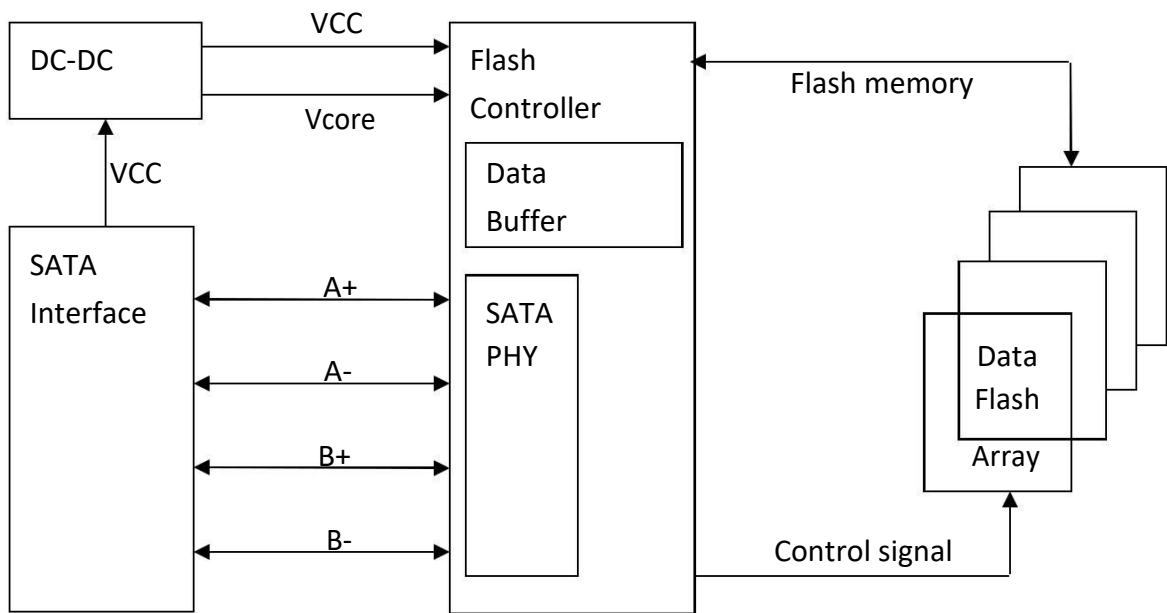

2.5" SATA SSD Block Diagram



2. PRODUCT SPECIFICATIONS

- **Capacity**



- SLC: From 32GB(30GB) up to 512GB(480GB) (support 48-bit addressing mode)
- MLC: From 64GB(60GB) up to 2TB(1920GB) (support 48-bit addressing mode)
- pSLC: From 32GB(30GB) up to 1TB(960GB) (support 48-bit addressing mode)
- 3D Bics3: From 128GB(120GB) up to 2TB(1920GB) (support 48-bit addressing mode)

- **Electrical/Physical Interface**

- SATA Interface
 - ◆ Compliant with SATA Revision 3.2
 - ◆ Compatible with SATA 1.5Gbps, 3Gbps and 6Gbps interface
 - ◆ NCQ support up to queue depth = 32
 - ◆ Support power management
 - ◆ Support expanded register for SATA protocol 48 bits addressing mode
 - ◆ Embedded BIST function for SATA PHY for low cost mass production

- **Supported NAND Flash**

- Toshiba SLC Legacy and Toggle
- Toshiba MLC, Toggle1.0 and Toggle2.0
- Support SLC large block 8K/page and MLC large block 16K/page NAND flash

- **ECC Scheme**

- Up to 120 bits / 2K Byte

- **Security (Optional)**

- AES 256 hardware encryption

- **UART function**

- **GPIO**

- **Support SMART and TRIM commands**

- **Support Hardware Quick Erase Function (Optional)**

- **Support Power Loss Protection (Optional)**

- Protect data loss, even the last data, during write process when power sudden off.
- Add-on Polymer Tantalum Capacitors hold-up several milliseconds to keep DRAM data write to NAND Flash.



● Capacity Information

Capacity	Cylinders	Heads	Sectors	Total Sectors	User Data Size
30GB	16,383	16	63	58,626,288	Depended on file management
32GB	16,383	16	63	62,533,296	
60GB	16,383	16	63	117,231,408	
64GB	16,383	16	63	125,045,424	
120GB	16,383	16	63	234,441,648	
128GB	16,383	16	63	250,069,680	
240GB	16,383	16	63	468,862,128	
256GB	16,383	16	63	500,118,192	
480GB	16,383	16	63	937,703,088	
512GB	16,383	16	63	1,000,215,216	
960GB	16,383	16	63	1,875,385,008	
1TB	16,383	16	63	2,000,409,264	
1920GB	16,383	16	63	3,750,748,848	
2TB	16,383	16	63	4,000,797,360	

● Performance

▪ SLC:

Capacity	Flash Structure	Flash Type	Sequential	
			Read (MB/s)	Write (MB/s)
32GB (30GB)	4GB x 8	24nm, TSOP	310	250
	8GB x 4	24nm, BGA	550	320
64GB (60GB)	8GB x 8	24nm, TSOP	320	300
	16GB x 4	24nm, BGA	550	500
128GB (120GB)	16GB x 8	24nm, TSOP	320	310
	32GB x 4	24nm, BGA	550	490
256GB (240GB)	32GB x 8	24nm, BGA	550	530
512GB (480GB)	32GB x 16	24nm, BGA	550	480



▪ **MLC:**

Capacity	Flash Structure	Flash Type	Sequential	
			Read (MB/s)	Write (MB/s)
64GB (60GB)	16GB x 4	15nm, TSOP	520	95
128GB (120GB)	16GB x 8	15nm, TSOP	520	200
256GB (240GB)	32GB x 8	15nm, BGA	520	400
512GB (480GB)	64GB x 8	15nm, BGA	520	500
1TB (960GB)	128GB x 8	15nm, BGA	520	500
2TB (1920GB)	128GB x 16	15nm, BGA	550	500

▪ **pSLC:**

Capacity	Flash Structure	Flash Type	Sequential	
			Read (MB/s)	Write (MB/s)
32GB (30GB)	16GB x 4	15nm, TSOP	530	300
64GB (60GB)	16GB x 8	15nm, TSOP	530	490
128GB (120GB)	32GB x 8	15nm, BGA	550	510
256GB (240GB)	64GB x 8	15nm, BGA	550	530
512GB (480GB)	128GB x 8	15nm, BGA	550	530
1TB (960GB)	128GB x 16	15nm, BGA	550	500

▪ **3D Bics3:**

Capacity	Flash Structure	Flash Type	Sequential	
			Read (MB/s)	Write (MB/s)
128GB (120GB)	64GB x 2	Bics3, BGA	550	150
256GB (240GB)	64GB x 4	Bics3, BGA	550	300
512GB (480GB)	64GB x 8	Bics3, BGA	550	520
1TB (960GB)	128GB x 8	Bics3, BGA	550	530
2TB (1920GB)	256GB x 8	Bics3, BGA	550	530

Notes:

1. The performance was estimated based on Toshiba SLC and MLC NAND flash.
2. Performance may differ according to flash configuration and platform.
3. The table above is for reference only.



- **TBW (Terabytes Written)**

- **SLC:**

Capacity	Flash Structure	TBW
32GB (30GB)	4GB x 8 8GB x 4	1284
64GB (60GB)	8GB x 8 16GB x 4	2568
128GB (120GB)	16GB x 8 32GB x 4	5136
256GB (240GB)	32GB x 8	10273
512GB (480GB)	32GB x 16	20547

- **MLC:**

Capacity	Flash Structure	TBW
64GB (60GB)	16GB x 4	128
128GB (120GB)	16GB x 8	257
256GB (240GB)	32GB x 8	514
512GB (480GB)	64GB x 8	1028
1TB (960GB)	128GB x 8	2057
2TB (1920GB)	128GB x 16	4114

- **pSLC:**

Capacity	Flash Structure	TBW
32GB (30GB)	16GB x 4	642
64GB (60GB)	16GB x 8	1284
128GB (120GB)	32GB x 8	2568
256GB (240GB)	64GB x 8	5136
512GB (480GB)	128GB x 8	10273
1TB (960GB)	128GB x 16	20547



▪ **3D Bics3:**

Capacity	Flash Structure	TBW
128GB (120GB)	64GB x 2	213
256GB (240GB)	64GB x 4	426
512GB (480GB)	64GB x 8	852
1TB (960GB)	128GB x 8	1704
2TB (1920GB)	256GB x 8	3408

Notes:

1. Samples were built using Toshiba SLC and MLC NAND flash.
2. TBW may differ according to flash configuration and platform.
3. The endurance of SSD could be estimated based on user behavior, NAND endurance cycles, and write amplification factor. It is not guaranteed by flash vendor.



3. ENVIRONMENTAL SPECIFICATIONS



3.1. Environmental Conditions

3.1.1. Temperature and Humidity

- Temperature:
 - ◆ Storage: -40°C to 85°C
 - ◆ Operational (Standard grade): 0°C to 70°C
 - ◆ Operational (Wide grade): -40°C to 85°C
- Humidity:
 - ◆ Standard grade: RH 90% under 40°C (operational)
 - ◆ Wide grade: RH 95% under 55°C (operational)

■ High Temperature Test Condition

	Temperature	Humidity	Test Time
Operation (Standard)	70°C	0% RH	72 hours
Operation (Wide)	85°C	0% RH	72 hours
Storage (Standard)	85°C	0% RH	72 hours
Storage (Wide)	85°C	0% RH	168 hours

Result: No any abnormality is detected.

■ Low Temperature Test Condition

	Temperature	Humidity	Test Time
Operation (Standard)	0°C	0% RH	72 hours
Operation (Wide)	-40°C	0% RH	72 hours
Storage (Standard)	-40°C	0% RH	72 hours
Storage (Wide)	-40°C	0% RH	168 hours

Result: No any abnormality is detected.

■ High Humidity Test Condition

	Temperature	Humidity	Test Time
Operation (Standard)	40°C	93% RH	24 hours
Operation (Wide)	55°C	95% RH	72 hours
Storage (Standard)	40°C	95% RH	72 hours
Storage (Wide)	55°C	95% RH	96 hours

Result: No any abnormality is detected.

■ Temperature Cycle Test



	Temperature	Test Time	Cycle
Operation (Standard)	0°C	30 min	10 cycles
	70°C	30 min	
Operation (Wide)	-40°C	30 min	20 cycles
	85°C	30 min	
Storage (Standard)	-40°C	30 min	10 cycles
	85°C	30 min	
Storage (Wide)	-40°C	30 min	50 cycles
	85°C	30 min	

Result: No any abnormality is detected.

3.1.2. Shock

■ Shock Specification

	Acceleration Force	Half Sin Pulse Duration
Non-Operational	1500G	0.5ms
Operational	1500G	0.5ms

Result: No any abnormality is detected when power on.

3.1.3. Vibration

■ Vibration Specification

	Condition		Vibration Orientation
	Frequency/Displacement	Frequency/Acceleration	
Operational	20Hz~80Hz/1.52mm	80Hz~2000Hz/20G	X, Y, Z axis/60 min for each

Result: No any abnormality is detected when power on.

3.1.4. Drop

■ Drop Specification

	Height of Drop	Number of Drop
Non-operational	80cm free fall	6 face of each unit, 2 times each

Result: No any abnormality is detected when power on.



3.1.5. Bending

■ Bending Specification

	Force	Action
Non-operational	≥ 20N	Hold 1min/5times

Result: No any abnormality is detected when power on.

3.1.6. Electrostatic Discharge (ESD)

■ Contact ESD Specification

Device	Capacity	Temperature	Relative Humidity	+/- 4KV	Result
HF3 2.5"SSD	256GB	24.0°C	49% (RH)	Device functions are affected, but EUT will be back to its normal or operational state automatically.	PASS

3.2. MTBF

MTBF, an acronym for Mean Time between Failures, is a measure of a device’s reliability. Its value represents the average time between a repair and the next failure. The measure is typically in units of hours. The higher the MTBF value, the higher the reliability of the device. The predicted result of Longline’s 2.5” SATA SSD is up to 5,000,000 hours.

3.3. Certification

- RoHS
- CE / FCC

3.4. Compliance

- SATA III (SATA Rev. 3.2)
- Up to ATA/ATAPI-8 (Including S.M.A.R.T)



4. ELECTRICAL SPECIFICATIONS



4.1. Supply Voltage

Parameter	Rating
Operating Voltage	5V ± 5%
Maximum Ripple	100mV, 0~30MHz

4.2. Power Consumption

▪ SLC

Capacity	Flash Structure	Flash Type	Read	Write	Partial	Slumber	Idle
32GG (30GB)	4GB x 8 8GB x 4	24nm, TSOP 24nm, BGA	2050 2100	2500 2500	65 65	55 60	170 170
64GB (60GB)	8GB x 8 16GB x 4	24nm, TSOP 24nm, BGA	2100 2200	2700 3200	65 70	60 65	170 170
128GB (120GB)	16GB x 8 32GB x 4	24nm, TSOP 24nm, BGA	2100 2200	2700 3300	65 65	55 65	170 170
256GB (240GB)	32GB x 8	24nm, BGA	2500	3700	75	70	180
512GB (480GB)	32GB x 16	24nm, BGA	3050	4070	260	260	370

Unit: mW

▪ MLC

Capacity	Flash Structure	Flash Type	Read	Write	Partial	Slumber	Idle
64GB (60GB)	16GB x 4	15nm, TSOP	2000	2300	200	200	200
128GB (120GB)	16GB x 8	15nm, TSOP	2060	2330	260	260	360
256GB (240GB)	32GB x 8	15nm, BGA	2150	3600	260	255	365
512GB (480GB)	64GB x 8	15nm, BGA	2235	4370	265	265	375
1TB (960GB)	128GB x 8	15nm, BGA	2520	4450	285	280	400
2TB (1920)	128GB x 16	15nm, BGA	3200	5400	280	260	400

Unit: mW

▪ pSLC



Capacity	Flash Structure	Flash Type	Read	Write	Partial	Slumber	Idle
32GB (30GB)	16GB x 4	15nm, TSOP	2000	2300	200	200	200
64GB (60GB)	16GB x 8	15nm, TSOP	2060	2330	260	260	360
128GB (120GB)	32GB x 8	15nm, BGA	2150	3600	260	255	365
256GB (240GB)	64GB x 8	15nm, BGA	2235	4370	265	265	375
512GB (480GB)	128GB x 8	15nm, BGA	2520	4450	285	280	400
1TB (960GB)	128GB x 16	15nm, BGA	3040	4450	285	280	400

Unit: mW

▪ **3D Bics3**

Capacity	Flash Structure	Flash Type	Read	Write	Partial	Slumber	Idle
128GB (120GB)	64GB x 2	Bics3, BGA	2100	2345	75	70	175
256GB (240GB)	64GB x 4	Bics3, BGA	2300	2510	80	75	180
512GB (480GB)	64GB x 8	Bics3, BGA	2165	2515	85	85	185
1TB (960GB)	128GB x 8	Bics3, BGA	2310	3075	110	110	210
2TB (1920)	256GB x 8	Bics3, BGA	2525	3205	115	110	220

Unit: mW

Notes:

1. It's average value of power consumption is achieved based on 100% conversion efficiency.
2. The measured power voltage is 5V.
3. Samples were built using Toshiba NAND flash and measured under normal temperature.
4. Sequential R/W is measured while testing 4000MB sequential R/W 5 times by CrystalDiskMark.
5. Power Consumption may differ according to flash configuration and platform.



5. INTERFACE



5.1. Pin Assignment and Descriptions

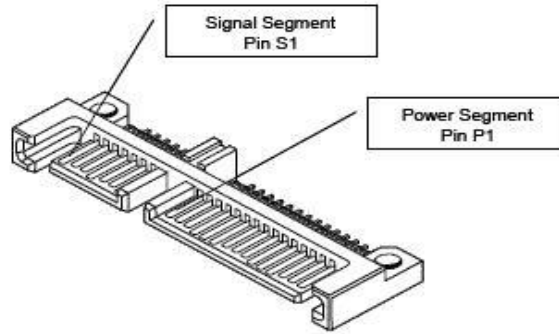

Assignment Signal Pin	Pin Number	Function
	S1	GND
	S2	A+ (Differential Signal Pair A)
	S3	A – (Differential Signal Pair A)
	S4	GND
	S5	B – (Differential Signal Pair B)
	S6	B+ (Differential Signal Pair B)
	S7	GND
Power Segment Pin Assignment	Pin Number	Function
	P1	Not Used (3.3V)
	P2	Not Used (3.3V)
	P3	DEVSLP
	P4	GND
	P5	GND
	P6	GND
	P7	5V pre-charge
	P8	5V
	P9	5V
	P10	GND
	P11	Reserved
	P12	GND
	P13	Not Used (12V pre-charge)
	P14	Not Used (12V)
P15	Not Used (12V)	



6. SUPPORTED COMMANDS



6.1. ATA Command List

Op-Code	Command Description	Op-Code	Command Description	
00h	NOP	60h	Read FPDMA Queued	
06h	Data Set Management	61h	Write FPDMA Queued	
10h	Recalibrate	70h	Seek	
20h	Read Sectors	90h	Execute Device Diagnostic	
21h	Read Sectors without Retry	91h	Initialize Device Parameters	
24h	Read Sectors EXT	92h	Download Microcode	
25h	Read DMA EXT	93h	Download Microcode DMA	
27h	Read Native Max Address EXT	B0h	SMART	
29h	Read Multiple EXT	B0h	D0h	SMART READ DATA
2Fh	Read Log EXT	B0h	D1h	SMART READ DATA ATTRIBUTE THRESHOLD
30h	Write Sectors	B0h	D2h	SMART ENABLE/DISABLE ATTRIBUTE AUTOSAVE
31h	Write Sectors without Retry	B0h	D3h	SMART SAVE ATTRIBUTE VALUES
34h	Write Sectors EXT	B0h	D4h	SMART EXECUTE OFF-LINE IMMEDIATE
35h	Write DMA EXT	B0h	D5h	SMART READ LOG
37h	Set Native Max Address EXT	B0h	D6h	SMART WRITE LOG
39h	Write Multiple EXT	B0h	D8h	SMART ENABLE OPERATIONS
3Dh	Write DMA FUA EXT	B0h	D9h	SMART DISABLE OPERATIONS
3Fh	Write Long EXT	B0h	DAh	SMART RETURN STATUS
40h	Read Verify Sectors	B0h	DBh	SMART ENABLE/DISABLE AUTOMATIC OFF-LINE
41h	Read Verify Sectors without Retry	B1h		DEVICE CONFIGURATION OVERLAY
42h	Read Verify Sectors EXT	B1h	C0h	DEVICE CONFIGURATION RESTORE
45h	Write Uncorrectable EXT	B1h	C1h	DEVICE CONFIGURATION FREEZE LOCK
47h	Read Log DMA EXT	B1h	C2h	DEVICE CONFIGURATION IDENTIFY
57h	Write Log DMA EXT	B1h	C3h	DEVICE CONFIGURATION SET
B1h	C4h	DEVICE CONFIGURATION IDENTIFY DMA	ECh	Identify Device
B1h	C5h	DEVICE CONFIGURATION SET DMA	EFh	Set Features
C4h	Read Multiple	EFh	02h	Enable 8-bit PIO transfer mode
Op-Code	Command Description	Op-Code	Command Description	
C5h	Write Multiple	EFh	03h	Set transfer mode based on value in



					Count field	
C6h		Set Multiple Mode	EFh	05h	Enable advanced power management	
C8h		Read DMA	EFh	10h	Enable use of Serial ATA feature	
C9h		Read DMA without Retry	EFh	10h	02h	Enable DMA Setup FIS Auto-Activate optimization
CAh		Write DMA	EFh	10h	03h	Enable Device-initiated interface power state (DIPM) transitions
CBh		Write DMA without Retry	EFh	10h	06h	Enable Software Settings Preservation (SSP)
CEh		Write Multiple FUA EXT	EFh	10h	07h	Enable Device Automatic Partial to Slumber transitions
E0h		Standby Immediate	EFh	10h	09h	Enable Device Sleep
E1h		Idle Immediate	EFh	55h		Disable read look-ahead feature
E2h		Standby	EFh	66h		Disable reverting to power-on defaults
E3h		Idle	EFh	82h		Disable write cache
E4h		Read Buffer	EFh	85h		Disable advanced power management
E5h		Check Power Mode	EFh	90h		Disable use of Serial ATA feature set
E6h		Sleep	EFh	90h	02h	Disable DMA Setup FIS Auto-Activate optimization
E7h		Flush Cache	EFh	90h	03h	Disable Device-initiated interface power state (DIPM) transitions
E8h		Write Buffer	EFh	90h	06h	Disable Software Settings Preservation (SSP)
E9h		Read Buffer DMA	EFh	90h	07h	Disable Device Automatic Partial to Slumber transitions
EAh		Flush Cache EXT	EFh	90h	09h	Disable Device Sleep
EBh		Write Buffer DMA	EFh	AAh		Enable read look-ahead feature
EFh	CCh	Enable reverting to power-on defaults	F4h			Security Erase Unit
F1h		Security Set Password	F5h			Security Freeze Lock
F2h		Security Unlock	F6h			Security Disable Password
F3h		Security Erase Prepare	F8h			Read Native Max Address



6.2. Identify Device Data

The following table details the sector data returned by the IDENTIFY DEVICE command.

Word	F: Fixed V: Variable X: Both	Default Value	Description
0	F	0040h	General configuration bit-significant information
1	X	*1	Obsolete – Number of logical cylinders
2	V	C837h	Specific configuration
3	X	0010h	Obsolete – Number of logical heads (16)
4-5	X	00000000h	Retired
6	X	003Fh	Obsolete – Number of logical sectors per logical track (63)
7-8	V	00000000h	Reserved for assignment by the Compact Flash Association
9	X	0000h	Retired
10-19	F	Varies	Serial number (20 ASCII characters)
20-21	X	0000h	Retired
22	X	0000h	Obsolete
23-26	F	Varies	Firmware revision (8 ASCII characters)
27-46	F	Varies	Model number (xxxxxxxx)
47	F	8010h	7:0- Maximum number of sectors transferred per interrupt on MULTIPLE commands
48	F	4000h	Reserved
49	F	2F00h	Capabilities
50	F	4000h	Capabilities
51-52	X	00000000h	Obsolete
53	F	0007h	Words 88 and 70:64 valid
54	X	*1	Obsolete – Number of logical cylinders
55	X	0010h	Obsolete – Number of logical heads (16)
56	X	003Fh	Obsolete – Number of logical sectors per track (63)
57-58	X	*2	Obsolete – Current capacity in sectors
59	F	0110h	Number of sectors transferred per interrupt on MULTIPLE commands
60-61	F	*3	Maximum number of sector (28bit LBA mode)
62	X	0000h	Obsolete
63	F	0407h	Multi-word DMA modes supported/selected
64	F	0003h	PIO modes supported
65	F	0078h	Minimum Multiword DMA transfer cycle time per word
Word	F: Fixed V: Variable	Default Value	Description



	X: Both		
66	F	0078h	Manufacturer's recommended Multiword DMA transfer cycle time
67	F	0078h	Minimum PIO transfer cycle time without flow control
68	F	0078h	Minimum PIO transfer cycle time with IORDY flow control
69	F	5F20h	Additional Supported
70	F	0000h	Reserved
71-74	F	0000000000000000 0h	Reserved for the IDENTIFY PACKET DEVICE command
75	F	001Fh	Queue depth
76	F	E70Eh	Serial SATA capabilities
77	F	0006/0004/0002h	Supported Serial ATA Phy speed
78	F	054Ch	Serial ATA features supported
79	V	0040H	Serial ATA features enabled
80	F	03F8h	Major Version Number
81	F	0000h	Minor Version Number
82	F	746Bh	Command set supported
83	F	7D09h	Command set supported
84	F	4163h	Command set/feature supported extension
85	V	7469h	Command set/feature supported or enabled
86	V	BC09h	Command set/feature supported or enabled
87	V	4163h	Command set/feature supported or enabled
88	V	007Fh	Ultra DMA Modes
89	F	0001h	Time required for Normal Erase mode SECURITY ERASE UNIT command
90	F	0001h	Time required for an Enhanced Erase mode SECURITY ERASE UNIT command
91	V	00FEh	Current advanced power management value
92	V	FFFEh	Master Password Revision Code
93	F	0000h	Hardware reset result. The contents of the bits (12:0) of this word can be changed only during the execution of hardware reset.
94	V	0000h	Vendor's recommended and actual acoustic management value
95	F	0000h	Stream Minimum Request Size
Word	F: Fixed V: Variable X: Both	Default Value	Description
96	V	0000h	Streaming Transfer Time – DMA



97	V	0000h	Streaming Access Latency – DMA and PIO
98-99	F	0000h	Streaming Performance Granularity
100-103	V	*4	Maximum user LBA for 48 bit Address feature set
104	V	0000h	Streaming Transfer Time – PIO
105	F	0008h	Maximum number of 512-byte blocks per DATA SET MANAGEMENT command
106	F	4000h	Physical sector size/Logical sector size
107	F	0000h	Inter-seek delay for ISO-7779 acoustic testing in microseconds
108-111	F	0000000000000000 0h	Unique ID
112-115	F	0000000000000000 0h	Reserved
116	V	0000h	Reserved
117-118	F	00000000h	Words per logical Sector
119	F	401Ch	Supported settings
120	F	401Ch	Command set/Feature Enabled/Supported
121-126	F	0h	Reserved
127	F	0h	Removable Media Status Notification feature set support
128	V	0021h	Security status
129-159	X	0h	Vendor specific
160	F	0h	Compact Flash Association (CFA) power mode 1
161-167	X	0h	Reserved for assignment by the CFA
168	F	3h 2.5 inch 4h 1.8 inch 5h Less than 1.8 inch	Device Nominal Form Factor
169	F	0001h	DATA SET MANAGEMENT command is supported
170-173	F	0h	Additional Product Identifier
174-175		0h	Reserve
176-205	V	0h	Current media serial number
206	F	0039h	SCT Command Transport(
207-208	F	0h	Reserved
209	F	4000h	Alignment of logical blocks within a physical block
Word	F: Fixed V: Variable X: Both	Default Value	Description
210-211	V	0000h	Write-Read-Verify Sector Count Mode 3 (not support)
212-213	F	0000h	Write-Read-Verify Sector Count Mode 2 (not support)
214-216		0000h	NV Cache relate (not support)



217	F	0001h	Non-rotating media device
218	F	0h	Reserved
219	F	0h	NV Cache relate (not support)
220	V	0h	Write read verify feature set current mode
221		0h	Reserved
222	F	107Fh	Transport major version number
223	F	0h	Transport minor version number
224-229		0h	reserved
230-233		0h	Extend number of user addressable sectors
234		0001h	Minimum number of 512-byte data blocks per DOWNLOAD MICROCODE command for mode 03h
235		FFFFh	Maximum number of 512-byte data blocks per DOWNLOAD MICROCODE command for mode 03h
236-242	F	0h	Reserved
243		4000h	Security feature 4000 : Self Encrypting Drive
244-254	F	0h	Reserved
255	X	XXA5h XX is variable	Integrity word (Checksum and Signature)



■ List of Device Identification for Each Capacity

Capacity (GB)	*1 (Word 1/Word 54)	*2 (Word 57–58)	*3 (Word 60–61)	*4 (Word 100–103)
30	3FFFh	FBFC10h	37E90F0h	37E90F0h
32	3FFFh	FBFC10h	3BA2EB0h	3BA2EB0h
60	3FFFh	FBFC10h	6FCCF30h	6FCCF30h
64	3FFFh	FBFC10h	7740AB0h	7740AB0h
120	3FFFh	FBFC10h	DF94BB0h	DF94BB0h
128	3FFFh	FBFC10h	EE7C2B0h	EE7C2B0h
240	3FFFh	FBFC10h	0FFFFFFFh	1BF244B0h
256	3FFFh	FBFC10h	0FFFFFFFh	1DCF32B0h
480	3FFFh	FBFC10h	0FFFFFFFh	37E436B0
512	3FFFh	FBFC10h	0FFFFFFFh	3B9E12B0h
960	3FFFh	FBFC10h	0FFFFFFFh	6FC81AB0h
1024	3FFFh	FBFC10h	0FFFFFFFh	773BD2B0h
1920	3FFFh	FBFC10h	0FFFFFFFh	DF8FE2B0h
2048	3FFFh	FBFC10h	0FFFFFFFh	EE7752B0h



6.3. Quick Erase Function (Optional)

- Firmware-based Features

Firmware-based Secure Erase is a standard ATA command, which will write all "0x00" to fully wipe all the data on hard drives and SSDs. When this command is issued, the SSD controller will erase its storage blocks and return to its factory default settings.

- Hardware-based Features

Hardware-Base Secure Erase is a special feature to allow users to erase user data of SSD by hardware trigger. When this feature is triggered by pin3 and pin4 short of pin header, the storage blocks of SSD will be erased and the SSD will return to its factory default setting. This feature is particularly useful for emergent circumstances to quickly erase user data.

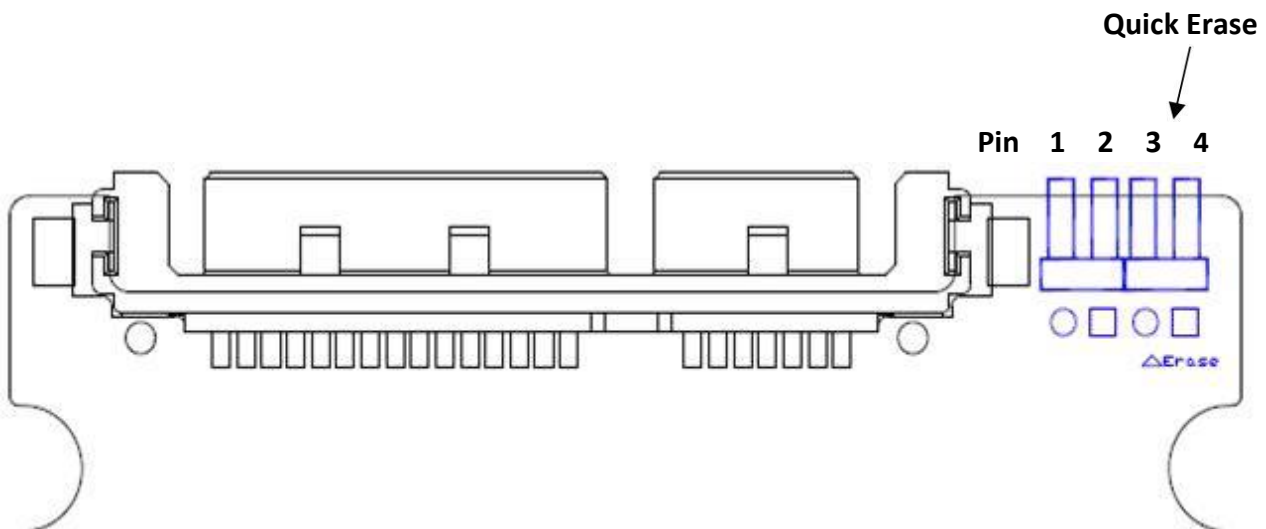



6.4. Write Protect Function (Optional)

- Hardware-based Features

Hardware-based write protect is special feature to allow users to protect user data cannot be revised and erased by hardware trigger. When this feature triggered by pin2 and pin3 short of pin header, all the write and erase command from the host will be reject by FW. This feature is useful for data protection application like gaming and KIOSK.

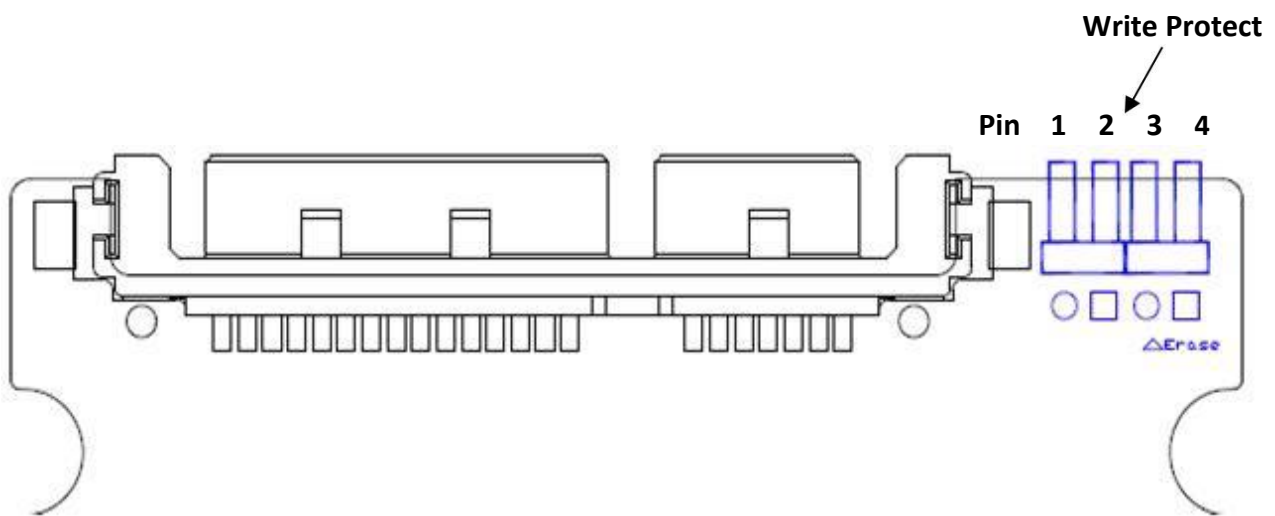

7. PHYSICAL DIMENSION

Dimension: 100.10mm(L) x 69.85mm(W) x 7.00mm(H)

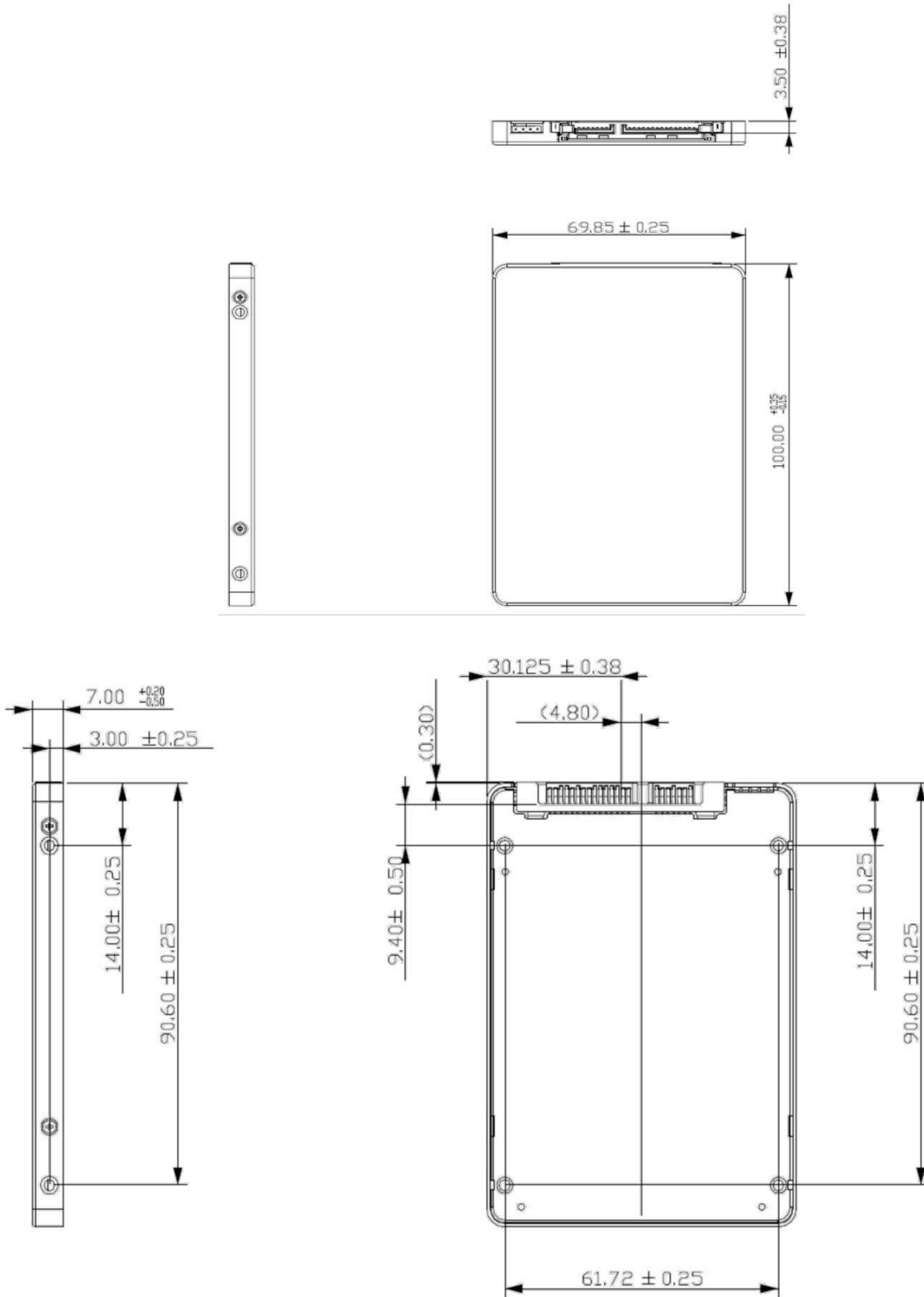



8. TERMINOLOGY



The following table is to list out the acronyms that have been applied throughout the document.

Term	Definitions
ATTO	Commercial performance benchmark application
DDR	Double data rate (SDRAM)
DIPM	Device initiated power management
HIPM	Host initiated power management
LBA	Logical block addressing
MB	Mega-byte
MTBF	Mean time between failures
NCQ	Native command queue
SATA	Serial advanced technology attachment
S.M.A.R.T.	Self-monitoring, analysis and reporting technology
SSD	Solid state disk