

Longline NVMe M.2 SSD Solid State Drive



Longline 256GB NVMe M.2 SATA SSD 2100/2100 MB/s LNG2100/256GN

LNG SSD LONGLINE SERIES PRODUCT DATASHEET



1.0 PRODUCT DESCRIPTION

1.1 PRODUCT OVERVIEW

LONGLINE, PCIe as a storage protocol is designed from the ground up to work with non-volatile memory (NVMe M.2), including the current NAND flash technology and next-generation NVM technologies. As such, it does not have the same limitations as storage protocols designed for hard disk drives.

PCIe protocol supports multiple deep queues, which is an advancement over traditional SAS and SATA protocols. Typical SAS devices support up to 256 commands and SATA devices support up to 32 commands in a single queue. These were adequate for hard disk drive technologies, but cannot take full advantage of current and next-generation NVM technologies.

In addition, PCIe has a streamlined and simple command set that uses less than half the number of CPU instructions to process an I/O request that SAS or SATA does, providing higher IOPS per CPU instruction cycle and lower I/O latency in the host software stack. PCIe also supports enterprise features such as reservations and client features such as power management, extending the improved efficiency beyond just I/O.

PCIe SSD drives provide more performance in terms of bandwidth and lower latency than SAS and SATA based counterparts.

1.2 TARGET APPLICATIONS

- Military and Aerospace
- Embedded / Industrial Systems
- Medical Industry
- Notebook
- Casino Gaming

1.3 PRODUCT FEATURES

- Native - PCIe SSD
- Capacity: 128GB, 256GB, 512GB, 1TB
- PCI Express Gen3: Single port X4 lanes
- Compliant with PCI Express Base Specification Rev. 3.0
- Compliant with NVM Express Specification Rev. 1.3



- Static and Dynamic Wear Leveling and Bad Block Management
- Support up to queue depth 64K
- LDPC + RAID
- Support for Toggle
- Support TLC NAND type flash
- Support SMART and TRIM commands
- 100% tested HW and SW

1.4 SYSTEM REQUIREMENTS

Operating Voltage Requirement: $V_{CC} = 3.3V \pm 5\%$

Operating System: Supported by all operating systems

Interface: Socket 3 (M key)

Installation Requirements:

- System Hardware which supports Socket 3 (M key) standards
- System Hardware includes M.2 socket or transfer board

2.0 PHYSICAL SPECIFICATIONS

2.1 MECHANICAL SPECIFICATIONS (SM2263XT PCBA)

Length: $80.0 \pm 0.2 \text{ mm}$

Width: $22.0 \pm 0.2 \text{ mm}$

Thickness: $2.20 \pm 0.2 \text{ mm}$

Weight: $7.0 \pm 0.2 \text{ g}$

Figure 1: M.2 PCIe 2280 Outline Drawing

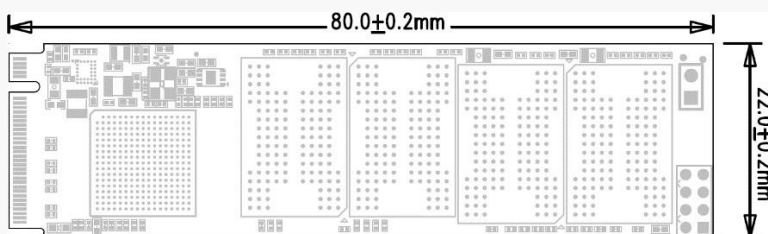



3.0 ELECTRICAL SPECIFICATIONS

Operating Voltage: $V_{CC} = 3.3V \pm 5\%$

Modes: PCIe 3.0

3.1 PERFORMANCE SPECIFICATIONS

Access Time: 0.2 ms

Seek Time: 0 ms

Mount Time: Dependent on system HW and SW

Power on to Ready: Dependent on system HW and SW

Data Transfer Time: Rated Data Transfer Speeds are maximums based on Crystal Disk Mark 6.0

* M.2 Port and the installation of an enhanced driver required for maximum speed

Table 1: Data Transfer Time Specifications up to :

Capacity	Data Transfer Speed (R / W) MB/s Up to			
	Seq. read	Seq. write	4K Q32T1 read	4K Q32T1 write
120GB/128GB B	1800	600	400	380
240GB/256GB B	1950	1200	700	400
480GB/512GB B	2000	1600	700	400
960GB/1TB	2100	1600	700	400

3.2 POWER AND TEMPERATURE CONDITIONS

Table 2: Absolute Maximum Ratings

Symbol	Rating	Value	Unit
VIN	Input Voltage	3.3V $\pm 5\%$	V
TSTG	Storage Temperature	-45 to 105	°C
TOPR	Commercial Grade	0 to +70	°C
	Industrial Grade	-40 to +85	°C



Table 3: Power consumption

Capacity	Product status(W)		
	Idle	Read	Write
120GB/128GB B	0.49	2.67	2.24
240GB/256GB B	0.48	2.89	2.83
480GB/512GB B	0.49	2.89	3.22
960GB/1TB	0.47	2.84	2.97

3.3 TOTAL BYTES WRITTEN

Table 4: TBW and Daily Usage Guideline results

Capacity	TB W	Daily Usage Guideline
120GB/128GB B	50TB	45GB/day
240GB/256GB B	100TB	90GB/day
480GB/512GB B	200TB	180GB/day
960GB/1TB	400TB	360GB/day

TBW: Total Bytes Written

Definition and conditions of TBW are based on JEDEC standard Daily usage guidelines value is calculated by dividing TBW by 365*3

4.0 ENVIRONMENTAL SPECIFICATIONS

Operating Temperature:
 Commercial Grade: 0°C to +70°C Industrial Grade: -40°C to +85°C **Humidity:**
 5% to ~98% RH **Operating Shock:** 1500G **Operating Vibration:** 16G **Operating Altitude:** TBD



5.0 QUALITY AND RELIABILITY SPECIFICATIONS

Data Retention: JESD47 compliant

Wear Leveling: Dynamic and static wear-leveling

Bad Block Management: Drive will self-identify bad blocks and remap physical to logical addresses to avoid bad blocks

ECC/EDC (Error Correction Code/Error Detection Code): Built in error detection and correction will correct physical bit errors in NAND. Drives use LDPC ECC

MTBF: >1,000,000 hours

6.0 COMPLIANCE SPECIFICATIONS

All PCIe are compliant with the following standards and regulations:

- RoHS
- CE
- FCC

7.0 PIN DESCRIPTIONS

7.1 M.2 INTERFACE DRAWING

Interface Description (M Key)

Figure 2: M.2 Interface Description

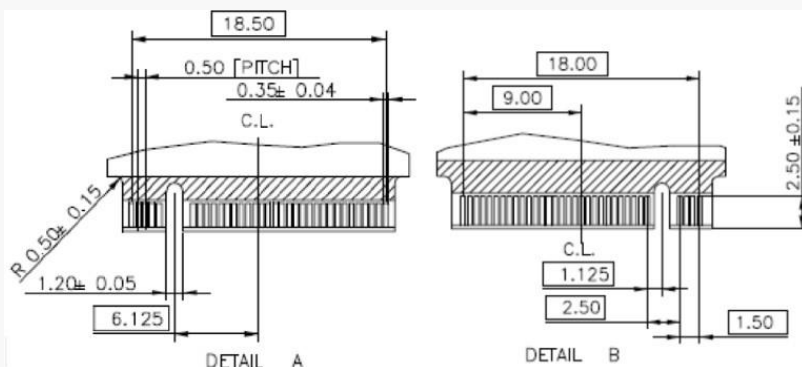

7.2 PIN SIGNALS ASSIGNMENTS

Table 5: Pin Assignment

1	GND	Return Current Path	2	+3.3V	3.3V Power (Source)
3	GND	Return Current Path	4	+3.3V	3.3V Power (Source)
5	PETn3	PCIe TX	6	N/A	Reserved
7	PETp3	PCIe TX	8	N/A	Reserved
9	GND	Return Current Path	10	LED1#	Device Activity Signal
11	PERn3	PCIe RX	12	+3.3V	3.3V Power (Source)
13	PERp3	PCIe RX	14	+3.3V	3.3V Power (Source)
15	GND	Return Current Path	16	+3.3V	3.3V Power (Source)
17	PETn2	PCIe TX	18	+3.3V	3.3V Power (Source)
19	PETp2	PCIe TX	20	N/A	Reserved
21	GND	Return Current Path	22	N/A	Reserved
23	PERn2	PCIe RX	24	N/A	Reserved
25	PERp2	PCIe RX	26	N/A	Reserved
27	GND	Return Current Path	28	N/A	Reserved
29	PETn1	PCIe TX	30	N/A	Reserved
31	PETp1	PCIe TX	32	N/A	Reserved
33	GND	Return Current Path	34	N/A	Reserved
35	PERn1	PCIe RX	36	N/A	Reserved
37	PETp1	PCIe RX	38	N/A	Reserved
39	GND	Return Current Path	40	N/A	Reserved
41	PETn0	PCIe TX	42	N/A	Reserved
43	PERP1	PCIe TX	44	N/A	Reserved
45	GND	Return Current Path	46	N/A	Reserved
47	PERn0	PCIe RX	48	N/A	Reserved
49	PERp0	PCIe RX	50	PERST#	PCIe Reset
51	GND	Return Current Path	52	CLKREQ#	PCIe Device Clock Request
53	REFCLKN	PCIe Reference Clock	54	PE Wake#	Reserved
55	REFCLKP	PCIe Reference Clock	56	N/A	Reserved
57	GND	Return Current Path	58	N/A	Reserved
59	Notch	M Key	60	Notch	M Key
61	Notch	M Key	62	Notch	M Key
63	Notch	M Key	64	Notch	M Key
65	Notch	M Key	66	Notch	M Key
67	N/A	Removed	68	SUSCLK	Reserved
69	PEDET	Removed	70	+3.3V	3.3V Power (Source)
71	GND	Return Current Path	72	+3.3V	3.3V Power (Source)
73	GND	Return Current Path	74	+3.3V	3.3V Power (Source)
75	GND	Return Current Path			



8.0 PCIE AND NVM EXPRESS REGISTERS

8.1 PCI EXPRESS REGISTERS

M.2 supports the command show in the following tables.

Table 6: Register Summary Table

Description	Start Address	End Address	Protocol
PCI Register Summary			
PCI Header	00h	3Fh	PCI Capability
PCI Power Management Capability	40h	47h	PCI Capability
MSI Capability	50h	67h	PCI Capability
PCI Express Capability	70h	A3h	PCI Capability
MSI-X Capability	B0h	BBh	PCI Capability
Advanced Error reporting Capability	100h	12Bh	PCI Capability
Device Serial NO Capability	148h	157h	PCI Capability
Power Budgeting Capability	158h	167h	PCI Capability
Secondary PCI Express Header	168h	17Bh	PCI Capability
Latency Tolerance Reporting(LTR)	188h	18Fh	PCI Capability
L1 Sub states Capability Register	190h	19Fh	PCI Capability
PCI Header Register Summary			
Identifiers	00h	03h	ID
Command Register	04h	05h	CMD
Device Status	06h	07h	STS
Revision ID	08h	08h	RID
Class Codes	09h	0Bh	CC
Cache Line Size	0Ch	0Ch	CLS
Master Latency Timer	0Dh	0Dh	MLT
Header Type	0Eh	0Eh	HTYPE
Built in Self-Test	0Fh	0Fh	BIST
Memory Register Base Address (lower 32-bit)	10h	13h	MLBAR (BAR0)
Memory Register Base Address (upper 32-bit)	14h	17h	MUBAR (BAR1)



Index/Data Pair Register Base Address	18h	1Bh	IDBAR (BAR2)
Reserved	1Ch	1Fh	BAR3
Reserved	20h	23h	BAR4
Reserved	24h	27h	BAR5
Card Bus CIS Pointer	28h	2Bh	CCPTR
Subsystem Identifiers	2Ch	2Fh	SS
Expansion ROM Base Address	30h	33h	EROM

Description	Start Address	End Address	Protocol
Capabilities Pointer	34h	34h	CAP
Reserved	35h	3Bh	R
Interrupt Information	3Ch	3Dh	INTR
Minimum Grant	3Eh	3Eh	MGNT
Maximum Latency	3Fh	3Fh	MLAT

PCI Power Management Capability Register Summary

PCI Power Management Capability ID	40h	40h	PID
Next capability	41h	41h	Next capability
PCI Power Management Capabilities	42h	43h	PMC
PCI Power Management Control and Status	44h	45h	PMCS
PMCSR_BSE Bridge Extensions	46h	46h	PMCSR_BSE
Data	47h	47h	Data

PCI Express Capability Register Summary

Description	Start Address	End Address	Symbol
PCI Express Capability ID	70h	71h	PXID
PCI Express Capabilities	72h	73h	PXCAP
PCI Express Device Capabilities	74h	77h	PXDCAP
PCI Express Device Control	78h	79h	PXDC
PCI Express Device Status	7Ah	7Bh	PXDS
PCI Express Link Capabilities	7Ch	7Fh	PXLCAP
PCI Express Link Control	80h	81h	PXLC
PCI Express Link Status	82h	83h	PXLS
PCI Express Device Capabilities 2	94h	97h	PXDCAP2
PCI Express Device Control 2	98h	99h	PXDC2
PCI Express Device Status 2	9Ah	9Bh	PXDS2
PCI Express Link Capabilities 2	9Ch	9Fh	PXLCAP2
PCI Express Link Control 2	A0h	A1h	PXLC2
PCI Express Link Status 2	A2h	A3h	PXLS2

Advanced Error Reporting Capability Register Summary

AER Capability ID	100h	103h	AERID
-------------------	------	------	-------



AER Uncorrectable Error Status	104h	107h	AERUCES
AER Uncorrectable Error Mask	108h	10Bh	AERUCEM
AER Uncorrectable Error Severity	10Ch	10Fh	AERUCES EV
AER Correctable Error Status	110h	113h	AERCES
AER Correctable Error Mask	114h	117h	AERCEM
AER Advanced Error Capabilities and Control	118h	11Bh	AERCC
AER Header Log	11Ch	12Bh	AERHL

Secondary PCI Express Capability Register Summary

Secondary PCI Express Capability	168h	16Bh	SPXID
PCI Express Link Control 3	16Ch	16Fh	PXLC3

Description	Start Address	End Address	Protocol
PCI Express Lane Error Status	170h	173h	PXLE
PCI Express Lane 0 Equalization Control	174h	175h	PXL0EC
PCI Express Lane 1 Equalization Control	176h	177h	PXL1EC
PCI Express Lane 2 Equalization Control	178h	179h	PXL2EC
PCI Express Lane 3 Equalization Control	17Ah	17Bh	PXL3EC

Secondary PCI Express Capability Register Summary

Secondary PCI Express Capability	168h	16Bh	SPXID
PCI Express Link Control 3	16Ch	16Fh	PXLC3
PCI Express Lane Error Status	170h	173h	PXLE
PCI Express Lane 0 Equalization Control	174h	175h	PXL0EC
PCI Express Lane 1 Equalization Control	176h	177h	PXL1EC
PCI Express Lane 2 Equalization Control	178h	179h	PXL2EC
PCI Express Lane 3 Equalization Control	17Ah	17Bh	PXL3EC

NVM Express Registers Register Summary

Controller Capabilities	00h	07h	CAP
Version	08h	0Bh	VS
Interrupt Mask Set	0Ch	0Fh	INTMS
Interrupt Mask Clear	10h	13h	INTMC
Controller Configuration	14h	17h	CC
Reserved	18h	1Bh	Reserved
Controller Status	1Ch	1Fh	CSTS
Reserved	20h	23h	Reserved
Admin Queue Attributes	24h	27h	AQA
Admin Submission Queue Base Address	28h	2Fh	ASQ



Admin Completion Queue Base Address	30h	37h	ACQ
Reserved	38h	EFFh	Reserved
Command Set Specific	F00h	FFFh	Reserved
Submission Queue 0 Tail Doorbell (Admin)	1000h	1003h	SQ0TDBL
Completion Queue 0 Head Doorbell (Admin)	1000h + (1 * (4 << CAP.DSTRD))	1003h + (1 * (4 << CAP.DSTRD))	CQ0HDBL
Submission Queue y Tail Doorbell	1000h + (2y * (4 << CAP.DSTRD))	1003h + (2y * (4 << CAP.DSTRD))	SQYTDVL
Completion Queue y Head Doorbell	1000h + ((2y + 1) * (4 << CAP.DSTRD))	1003h + ((2y + 1) * (4 << CAP.DSTRD))	CQYHDBL

9.0 SUPPORTED COMMAND SET

Table 7: Opcode for Admin Commands

Command Name	Opcode (Hex)
Delete I/O Submission Queue	00h
Create I/O Submission Queue	01h
Get Log Page	02h
Delete I/O Completion Queue	04h
Create I/O Completion Queue	05h
Identify	06h
Abort	08h
Set Feature	09h
Get Feature	0Ah
Asynchronous Event Request	0Ch
Firmware Activate	10h
Firmware Image Download	11h
Not used (I/O Command Set Specific)	80h —BFh
Not used (Vendor Specific)	C0h —FFh
Format NVM	80h
Security Send	81h
Security Receive	82h

Table 8: Identify Command Table Information

Description	Bytes	O/M	Default Value
PCI Vendor ID	1:00	M	tbd
PCI Subsystem Vendor ID	3:02	M	tbd
Serial Number (ASCII), #:Variables	23:04	M	tbd
Model Number (ASCII)	63:24:0 0	M	(see PN table)



Firmware Revision, #:Variables	71:64	M	tbd
Recommended Arbitration Burst	72	M	tbd
IEEE OUI	75:73	M	tbd
Controller Multi-path I/O and Name space Sharing Bit 2: 1h - Controller is associated with an SR-IOV Virtual Function 0h - Controller is associated with a PCI Function. Bit 1: 1h - Device has Two or More controller 0h - Device has One Controller Bit 0: 1h - Device has Two or More physical PCI Express ports 0h - Device has One PCI Express port	76	O	tbd
Maximum Data Transfer Size Bit 0: 1h - Supported (dual port—future value) 0h - Not Support (Single Port) Maximum Data Transfer Size (MDTS)	77	M	tbd

Description	Bytes	O/M	Default Value
Controller ID (CNTLID)	79:78	M	tbd
Reserved	255:80	M	tbd
Optional Admin Command Support Bits 15:3 - Reserved Bit 3: 1h - Name space Management and Name space Attachment Commands Supported (PM953 conditionally supports the Name space Management and Name space Attachment command(PCle v1.2 specification) for are configurable over provisioning) Bit 2: 1h — Firmware Activate/Download Supported Bit 1: 1h Format NVM Supported Bit 0: 0 Security Send and Security Receive Not Supported	257:256	M	tbd
Abort Command Limit (Maximum number of concurrently outstanding Abort commands) (0's based value)	258	M	tbd
Asynchronous Event Request Limit (Maximum number of concurrently outstanding Asynchronous Event Request commands) (0's based value)	259	M	tbd
Firmware Updates Bits 7:4—Reserved Bits 3:1 — Number of firmware slots Bit 0—1h Slot 1 is read only	260	M	tbd
Log Page Attributes Bits 7:1 —Reserved Bit 0: 0h SMART data is global for all name spaces	261	M	tbd



Error Log Page Entries (Number of Error Information log entries stored by controller) (0's based value)	262	M	tbd
Number of Power States Support (0's based value)	263	M	tbd
Admin Vendor Specific Command Configuration Bits 7:1 —reserved Bit 0 — Indicates Admin Vendor Specific Commands use the format defined in NVM Express 1.0c Figure 8	264	M	tbd
Autonomous Power State Transition Attributes (APSTA)	265	O	tbd
Reserved	511:266	-	-
Submission Queue Entry Size Bits 7:4 —6h Max SQES (64 bytes) Bits 3:0 —6h Required SQES (64 bytes)	512	M	tbd
Completion Queue Entry Size Bits 7:4 —4h Max SQES (16 bytes) Bits 3:0 —4h Required SQES (16 bytes)	513	M	tbd
Reserved	515:514	-	tbd

Description	Bytes	O/M	Default Value
Number of Name spaces	519:516	M	tbd
Optional NVM Command Support Bits 15:6 — Reserved Bit 5 —1h Reservations Supported 0h Not support Reservations Bit 4 —1h Save field in Set Feature & Select field in Get Feature Supported 0h Not support Save field in Set Feature & Select field in Get Feature Bit 3 — 1h Write Zeros Supported 0h Not support Write Zeros Bit 2 — 1h Data set Management Supported 0h Not support Data set Management Bit 1 —1h Write Uncorrectable Supported 0h Not support Write Uncorrectable Bit 0 —1h Compare Supported 0h Not support Compare	521:520	M	tbd
Fused Operation Support Bits 15:1 — Reserved Bit 0 —0h Compare/Write Fused Operation Not Supported	523:522	M	tbd
Format NVM Attributes Bits 7:3 —Reserved Bit 2 —1h Cryptographic Erase Bit 1 —1h Secure Erase Per Name Space Bit 0 — 0h Format Per Name space	524	M	tbd
Volatile Write Cache 0h —No VWC present	525	M	tbd
Atomic Write Unit Normal	527:526	M	tbd
Atomic Write Unit Power Fail (0's based value)	529:528	M	tbd



NVM Vendor Specific Command Configuration Bits 7:1 —reserved Bit 0 — Indicates NVM Vendor Specific Commands use the format defined in NVM Express 1.1.a	530	M	tbd
Reserved	531	M	tbd
ACWU	533:532	O	tbd
Reserved	534:533	M	tbd
No SGL support	539:536	O	tbd
Reserved	703:540	-	tbd
Reserved	2047:704	-	tbd
Power State 0 Descriptor	2079:2048	M	refer to 'Identify Power State Descriptor Data Structure'
N/A	2111:2080	O	tbd
N/A	2143:2112	O	tbd
N/A	-	-	tbd
Power State 31 Descriptor (N/A)	3071:3040	O	tbd
Reserved	4095:3072	1	-



10.0 INSTALLATION

BEFORE GETTING STARTED

1. Back Up Your Data

VISUAL INSPECTION

1. Before unpacking and handling the SSD, discharge the static electricity by touching the metal chassis of your computer or by using an anti-static wrist strap
2. Inspect the box and device for the following
 - a. Box is damaged or water-stained
 - b. Any damage to the SSD

HANDLING THE SSD

1. Be cautious when unpacking, installing, and handling the SSD drive. Misuse of the SSD voids all warranty. Follow the succeeding instructions when managing the SSD
2. Follow all ESD precautions
3. Always operate the SSD within environmental conditions
4. Never switch DC power to the drive by plugging an electrically live source cable into the drive's power connector

INSTALLATION

System Requirements

To install the SSD in your computer, ensure that you have the following items:

1. Mounting Screws (If needed)

Install the SSD

Follow these steps to install the SSD

1. Power down the PC
2. Remove the computer system outside cover
3. Insert the SSD to the connector on motherboard
4. Replace the PC cover
5. Power on the PC



6. A BIOS sign-on message appears and displays a key sequence to enter the BIOS setup. Set up the BIOS to recognize the SSD.
7. Installation is Complete

USING THE SSD IN A MS-DOS OS

The SSD is already partitioned and formatted by NTFS, so if you want to install MS-DOS O/S on the SSD, it should be re-partitioned and re-formatted. After installing the SSD, it must be installed as a disk drive under DOS. Run the DOS commands as listed below and follow the instructions displayed for each command.

1. Run the DOS FDISK program to partition the SSD
2. Verify that the partition is active and ready for formatting
3. Run the DOS FORMAT command to high-level format the SSD

USING THE SSD IN A WINDOWS OS

No modifications need to be made to use the SSD in a Windows OS platform

USING THE SSD IN A LINUX O/S

Port driver is needed to be made to use the SSD in Linux OS platforms. please contact Super Talent technical support for more detail.

USING THE SSD IN OTHER O/S

Port driver is needed to be made to use the SSD in other OS platforms. please contact Super Talent technical support for more detail.